



**NOX
CYC
LES**
NOXCYCLES.COM



THE NEXT GENERATION 2019

NO
MORE
EXCUSES.



PERFECT E-BIKE.
PERFECT DAY.

We at Nox Cycles are manufacturers of high-tech e-bikes. We are driven by a passion to build the best electric mountain bikes around. Our guiding principle is to offer every customer top quality and individuality.

Nox hybrid e-mountain bikes take freedom and adventure to a whole new level.

OUR FACTORY

BERLIN-ZILLERTAL. THE BEST OF BOTH WORLDS.

The Nox Cycles brand was created in Berlin in 2004, based on our passion and ambition to produce competition-capable gravity bikes equipped with top-of-the-line components and assemblies.

Since the 2016 season, we have been focusing exclusively on developing and producing high-quality electric mountain bikes at our new production site in the heart of the Austrian Alps.

DESIGNED IN GERMANY.
MADE IN AUSTRIA.



FROM IDEA TO FINISHED BIKE – A LONG TRAIL

Many of Nox's ideas and improvements are conceived on the trail, while others result from the many years of experience of our employees, testers and team riders. We at Nox Cycles work hard each day to develop these ideas through to production and bring them back onto the trail. Each stage of this process – from product design, to prototype construction, to series production – must be given the same level of attention, as they all contribute to the bike's strong character and its resilience on the trail.

NEXT GENERATION

BUILDING THE SWEETEST HYBRID BIKE

The Nox Cycles team endeavoured – almost obsessively – to perfect every last detail when developing the new bike generation. Finite-element load analyses, optimised calculations for kinematics simulations, coordination of form and colour – nothing was left to chance, and everything was relentlessly tested on all trails until theory and practice were in perfect harmony. Practically no stone was left unturned – from the battery system, to geometry and styling, through to colouring and equipment lines.

THE RESULT:
the perfect e-bike.



XC Trail 27,5"+/29"
LONG AND LAID-BACK. 120mm/130mm

You enjoy long, laid-back rides on 29" tyres, but would you also like to ride technical trails with 27.5" wheels on the same bike? Then turn to page 13



All Mtn 5.9 27,5"+/29"
THROUGH THICK & THIN. 150mm/160mm

Looking for an e-mountain bike that's a true all-rounder and can accompany you on all your rides, be it your regular tour or an alpine crossing? Then turn to page 21



Enduro 7.1 27,5"+/29"
OVER ROUGH AND ROCK. 180mm

Do you like extreme, long rides on single trails and over rough terrain? Do you want to have fun riding both uphill and downhill? Then turn to page 29

TECH&DESIGN

HYBRID



As with its predecessor, the declared objective for the new Nox Hybrid e-mountain bike range was to equip the bikes to the highest standard and optimise them for climbs and, above all, descents in challenging terrain. All hardtail, All-Mountain and Enduro bikes are therefore supplied with a Brose electric drive, because we believe the symbiosis between muscle power and electric propulsion – the hybrid drive – is the future of mountain biking.



NOX R&D

NOX R&D

The Design department at Nox Cycles is responsible for continuously developing and perfecting our e-mountain bikes – from the frame geometry to the very last detail. Only when everything is absolutely consistent the next development step initiates: the prototype phase, during which the skills of the test riders are called for in particular. And only after every necessary improvement – no matter how small – has been documented and implemented, and the test riders themselves are satisfied, is series production given the green light.



BROSE ePOWER

BROSE E-POWER

Nox Hybrid bikes are not only distinguished by their attractive appearance, extreme robustness and outstanding handling, but, above all else, a perfectly integrated drive system that meets the tough demands of mountain biking. With the new Brose Drive S mid-mounted motor and a battery capacity of up to 630 Wh, no ride is too long and no climb too high for the Nox HYBRID bikes.

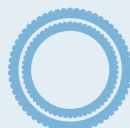

DWP 27,5"/29

DOUBLE WHEEL PERFORMANCE

Thanks to flip chips on the dropouts, all bikes can be equipped with 27.5" or 29" wheels (Boost standard), providing the ideal basis for a wide application range, extending from long alpine tours to after-work rides on technical trails.

MODERN GEOMETRY FOR PERFECT RIDE CHARACTERISTICS

Long wheelbase, flat steering angle, short chain stays

NEW COLOURS, SURFACES, DECOR



DESIGN EVOLUTION

New shapes, colours, surfaces and decor that nevertheless remain true to the unmistakable Nox design language

CABLE ROUTING

neat and tidy appearance thanks to integrated cable routing

FLEXIBLE TYRE SELECTION

- ▶ Tyre width up to 2.8" (for 27.5"+) with Boost standard
- ▶ Wheel size (27.5" / 29") with flip chip

OPTIMISED MOTOR POSITION

Harmonious solution integrated perfectly into the frame and overall design

QUIET, INTUITIVE HIGH-PERFORMANCE MOTOR

With its high torque and responsiveness (36V, 250W, 3,400g), the Brose Drive S mid-mounted motor ensures powerful yet natural riding pleasure

FULLY INTEGRATED HIGH-PERFORMANCE REPLACEABLE BATTERY

Greater range thanks to the new lithium-ion battery from BMZ (630Wh, URV8, 50 cells). The fully integrated battery has a compact design and can be removed from below.

EQUIPMENT OPTIMISED FOR E-BIKES

All series e-bikes are equipped uncompromisingly to meet the demands posed by challenging terrain



DRIVE UNIT

brose
Competence in Mechatronics

PARTNERS

In close collaboration with the established e-mobility companies, Brose and BMZ, our developers and designers have integrated the powerful battery and the electric motor in the optimum areas of the sophisticated frame geometry. Nox Hybrid bikes are not only distinguished by their attractive appearance, extreme robustness and outstanding handling, but also and above all by a perfectly integrated drive system that meets the tough demands of mountain biking.

drive
S

PEAK PERFORMERS

E-mountain bikes must offer precise response, particularly on technical and rocky trails. The finely tuned sensors of the Drive S provide the ideal amount of additional power at just the right moment. This results in natural and intuitive riding pleasure and an authentic MTB experience – even in extreme conditions.

QUIET PROPULSION

Whether in the forest or on a mountain pass – every noise from the motor can spoil the enjoyment of nature. Something that the engineers at Brose considered as well. With success! The motor remains virtually silent, even on steep climbs and at high speed!

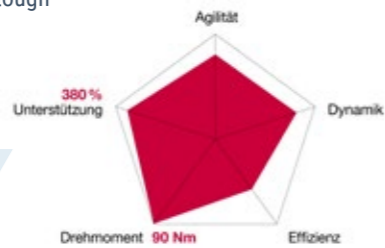
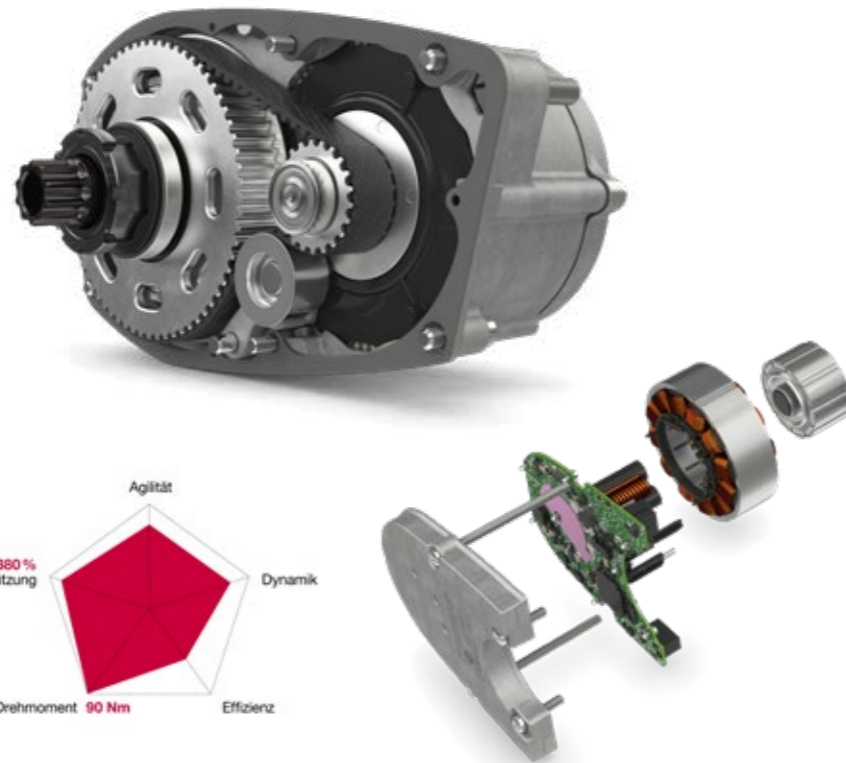

TECHNICAL DATA

▶ Dimensions	213 x 150 x 128 mm
▶ Weight	3,400 g
▶ Motor type	mid-mounted
▶ Rated voltage	36 V
▶ Continuous rated power	250 W
▶ Pedelec support	up to 25 km/h
▶ Push-assist	up to 6 km/h



BMZ
DRIVE SYSTEMS

BMZ URV8 FOR DEMANDING LOAD SCENARIOS

The URV8 battery has a highly effective mounting mechanism and works reliably even under demanding load scenarios. The URV8's aluminium housing and mounting bracket are robust and resilient. The fully integrated battery has a compact design and can be removed from below. It is built using BMZ Top cells, which have a very high energy density and a service life of up to twelve years. The URV8 has a peak performance of 30A, 630Wh and is available with a rated voltage of 36V. This makes the URV8 a high-performance solution ready for the new generation of e-bike motors.

PERFORMANCE DATA

▶ Energy content	50 lithium-ion cells / 36.0V
▶ Capacity	17.5 Ah
▶ Discharge contact	Blade contact
▶ Lockable	yes
▶ Weight	approx. 3,900 g

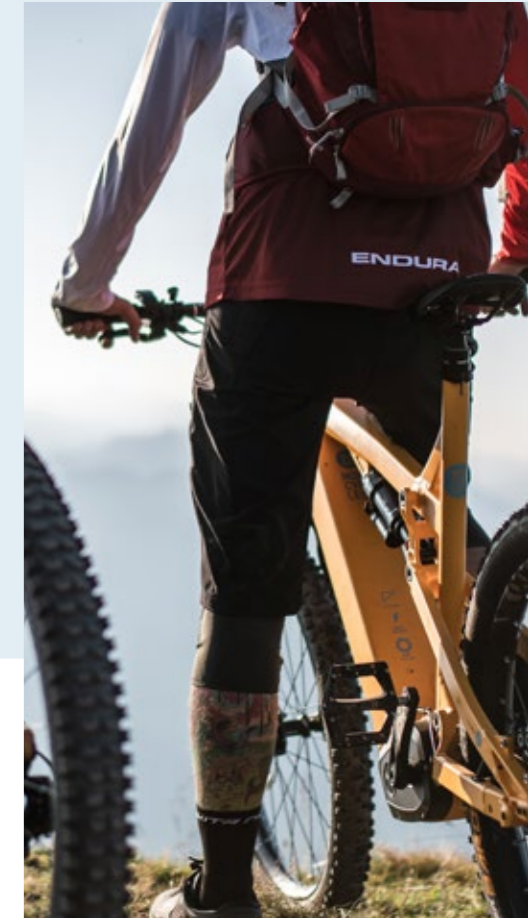

THERE'S A REASON
WE DON'T SEE THE
WORLD IN BLACK
AND WHITE.

- CELERIE KEMBLE





XC

NOX HYBRID **XC TRAIL** LONG AND LAID-BACK.

You enjoy long, laid-back rides on 29" tyres, but would you also like to ride technical trails with 27.5" wheels on the same bike? Are you tired of wearing yourself out on climbs and not having enough energy left to make it further on your cross-country tours? Would you like to ride a trail e-bike that's equipped to the highest standard but is still affordable?

If your answer to these questions is **YES**, then we have the perfect bike for you: the new Nox HYBRID XC TRAIL – a bike for everyone who wants to push themselves beyond their limits.

DETAILS

- ▶ Wheel sizes 27.5" / 29"
- ▶ Suspension travel (front) 130mm
- ▶ Brose Drive S Alu mid-mounted motor (36V, 250W)
- ▶ BMZ URV8 battery (630Wh)
- ▶ Cross-country-specific components
- ▶ Mounts for kick-stand, panniers, mudguards and water bottle

MIDNIGHT

SIERRA

XC

CROSS
COUNTRY

SIERRA



MIDNIGHT



XC PRO

DRIVE		EQUIPMENT		€ 4.799,- *	
CRANKSET	SRAM EX1 E-Crank, 165mm, 34T	FRAME	NOX XC Trail Hybrid	SEAT POST	ROCK SHOX Reverb
REAR DERAILLEUR	SRAM GX Eagle 12fach	FRAME SIZES	S / M / L / XL	SADDLE	Stealth, 30.9, 1X
SHIFTER	SRAM GX Eagle 12fach	FORK	FOX Performance 34 E-Bike, 29"/27.5"+, 120mm	WHEELSET	DT SWISS H1700 Spline 29
CASSETTE	SRAM PG 1230, 11-50T	STEM	TRUVATIV Stylo T20 75mm	TYRES	CONTINENTAL Mountain King III 29x2.3 Protection
MOTOR	BROSE Drive-S Unit	HANDLEBAR	TRUVATIV Stylo T20 700mm	BRAKES	MAGURA MT5
BATTERY	BMZ Inside UR-V8, 10S5P, 630Wh	GRIPS	ERGON GA30		
CHARGER	BMZ Ladegerät 10S, 4.5A WBE (100 -240V)				

XC EXPERT

DRIVE		EQUIPMENT		€ 3.799,- *	
CRANKSET	SRAM EX1 E-Crank, 165mm, 34T	FRAME	NOX XC Trail Hybrid	SEAT POST	NOX Components
REAR DERAILLEUR	SRAM GX 11fach	FRAME SIZES	S / M / L / XL	SADDLE	30.9mm/400mm
SHIFTER	SRAM GX 11fach	FORK	ROCK SHOX Recon RL 29"/27.5"+, 130mm	WHEELSET	DT SWISS H1900 Spline 29
CASSETTE	SRAM PG-1130, XG1150, 11-42T	STEM	NOX Components 70mm	TYRES	CONTINENTAL Mountain King III 29x2.3 Protection
MOTOR	BROSE Drive-S Unit	HANDLEBAR	NOX Components 700mm	BRAKES	MAGURA MT5
BATTERY	BMZ Inside UR-V8, 10S5P, 630Wh	GRIPS	ERGON GA30		
CHARGER	BMZ Ladegerät 10S, 4.5A WBE (100 -240V)				

XC COMP

DRIVE		EQUIPMENT		€ 3.299,- *	
CRANKSET	SRAM EX1 E-Crank, 165mm, 34T	FRAME	NOX XC Trail Hybrid	SEAT POST	NOX Components
REAR DERAILLEUR	SRAM NX 11fach	FRAME SIZES	S / M / L / XL	SADDLE	30.9mm/400mm
SHIFTER	SRAM NX 11fach	FORK	ROCK SHOX Judy Silver TK 29"/27.5"+, 120mm	WHEELSET	DT SWISS H1900 Spline 29
CASSETTE	SRAM PG-1130, 11-42T	STEM	NOX Components 70mm	TYRES	CONTINENTAL Mountain King III 29x2.3 Performance
MOTOR	BROSE Drive-S Unit	HANDLEBAR	NOX Components 700mm	BRAKES	MAGURA MT2
BATTERY	BMZ Inside UR-V8, 10S5P, 630Wh	GRIPS	ERGON GA20		
CHARGER	BMZ Ladegerät 10S, 4.5A WBE (100 -240V)				

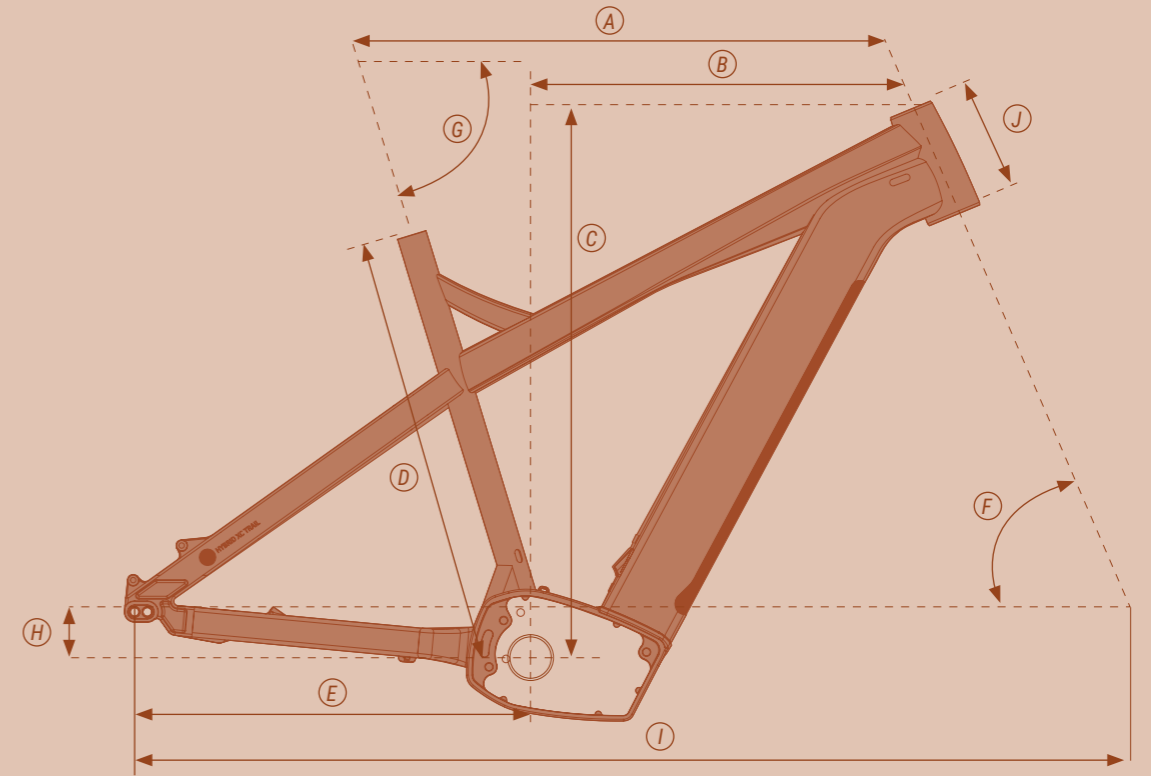

	S		M		L		XL	
	27.5"	29"	27.5"	29"	27.5"	29"	27.5"	29"
A Top tube (horizontal)	591mm	591mm	611mm	611mm	634mm	634mm	654mm	654mm
B Reach	403mm	403mm	422mm	422mm	443mm	443mm	463mm	463mm
C Stack	635mm	635mm	635mm	635mm	644mm	644mm	644mm	644mm
D Seat tube	395mm	395mm	435mm	435mm	480mm	480mm	530mm	530mm
E Chain stay	448mm	463mm	448mm	463mm	448mm	463mm	448mm	463mm
F Steering angle	67°	67°	67°	67°	67°	67°	67°	67°
G Seat angle	72°	72°	72°	72°	72°	72°	72°	72°
H BB drop	43mm	43mm	43mm	43mm	43mm	43mm	43mm	43mm
I Wheelbase	1159mm	1174mm	1179mm	1194mm	1203mm	1218mm	1223mm	1238mm
J Head tube	125mm	125mm	125mm	125mm	135mm	135mm	135mm	135mm

* Prices and equipment subject to change



5.9

NOX HYBRID **ALL-MOUNTAIN 5.9** THROUGH THICK AND THIN.

Looking for an e-mountain bike that's a true all-rounder and can accompany you on all your rides, be it your regular tour or an alpine crossing? Are you tired of wearing yourself out on climbs or being dependent on lifts? Are you looking for a reliable and robust bike with top components at a really fair price?

If your answer to these questions is **YES**, then we have the perfect bike for you: the NOX HYBRID ALL-MOUNTAIN 5.9 with 150mm suspension travel. A bike that goes through thick and thin with you on every ride!

DETAILS

- ▶ Wheel sizes 27.5" / 29"
- ▶ Suspension travel 150mm
- ▶ Brose Drive S Alu mid-mounted motor (36V, 250W)
- ▶ BMZ URV8 battery (630Wh)
- ▶ All-Mountain-specific components
- ▶ Water bottle mounts

BLUEBERRY

PUMPKIN

5.9

ALL-MOUNTAIN



PUMPKIN



BLUEBERRY



5.9 PRO

DRIVE		EQUIPMENT		€ 6.399,- *	
CRANKSET	SRAM EX1 E-Crank, 165mm, 34T	FRAME	NOX Frame 5.9 Hybrid	SEAT POST	FOX Transfer Factory Post
REAR DERAILLEUR	SRAM X0 Eagle 12fach	FRAME SIZES	S / M / L / XL	SADDLE	PROLOGO Proxim W650
SHIFTER	SRAM X0 Eagle 12fach	FORK	FOX 36 Factory E-Bike, 29"/27.5"+, 160mm		Microfiber P1 + Grip
CASSETTE	SRAM PG 1230, 11-50T	REAR SHOCK	FOX Float X2 Factory	WHEELSET	STAN'S NoTubes Sentry
MOTOR	BROSE Drive-S Unit	STEM	RENTHAL Apex 35		Team 27.5
BATTERY	BMZ Inside UR-V8, 10S5P, 630Wh	HANDLEBAR	RENTHAL Fatbar Lite 35	TYRES	CONTINENTAL Der Baron/ TrailKing 27.5x2.6
CHARGER	BMZ Ladegerät 10S, 4.5A WBE (100 -240V)	GRIPS	ERGON GE10 Evo	BRAKES	ProTaction Apex MAGURA MT7 HC

5.9 EXPERT

DRIVE		EQUIPMENT		€ 4.999,- *	
CRANKSET	SRAM EX1 E-Crank, 165mm, 34T	FRAME	NOX Frame 5.9 Hybrid	SEAT POST	ROCK SHOX Reverb Stealth, 30.9, 1X
REAR DERAILLEUR	SRAM NX Eagle 12fach	FRAME SIZES	S / M / L / XL	SADDLE	ERGON SM10 E
SHIFTER	SRAM NX Eagle 12fach	FORK	ROCK SHOX Revelation RC, 29"/27.5"+, 150mm	WHEELSET	DT SWISS H1900 Spline 27.5
CASSETTE	SRAM PG 1230, 15-50T	REAR SHOCK	ROCK SHOX Super Deluxe RC3		CONTINENTAL Der Baron/ TrailKing 27.5x2.6
MOTOR	BROSE Drive-S Unit	STEM	TRUVATIV Descendant 35	TYRES	ProTaction Apex
BATTERY	BMZ Inside UR-V8, 10S5P, 630Wh	HANDLEBAR	TRUVATIV Descendant 35	BRAKES	MAGURA MT5 HC
CHARGER	BMZ Ladegerät 10S, 4.5A WBE (100 -240V)	GRIPS	ERGON GA20		

5.9 COMP

DRIVE		EQUIPMENT		€ 4.399,- *	
CRANKSET	SRAM EX1 E-Crank, 165mm, 34T	FRAME	NOX Frame 5.9 Hybrid	SEAT POST	NOX Components
REAR DERAILLEUR	SRAM GX 11fach	FRAME SIZES	S / M / L / XL		30.9mm/400mm
SHIFTER	SRAM GX 11fach	FORK	ROCK SHOX Sektor RL, 29"/27.5"+, 150mm	SADDLE	ERGON SM10
CASSETTE	SRAM PG-1130, 11-42T,	REAR SHOCK	ROCK SHOX Deluxe RL	WHEELSET	DT SWISS H1900 Spline 27.5
MOTOR	BROSE Drive-S Unit	STEM	NOX COMPONENTS 35		TrailKing 27.5x2.6
BATTERY	BMZ Inside UR-V8, 10S5P, 630Wh	HANDLEBAR	NOX COMPONENTS 35	TYRES	ProTaction Apex
CHARGER	BMZ Ladegerät 10S, 4.5A WBE (100 -240V)	GRIPS	ERGON GA20	BRAKES	MAGURA MT5 HC

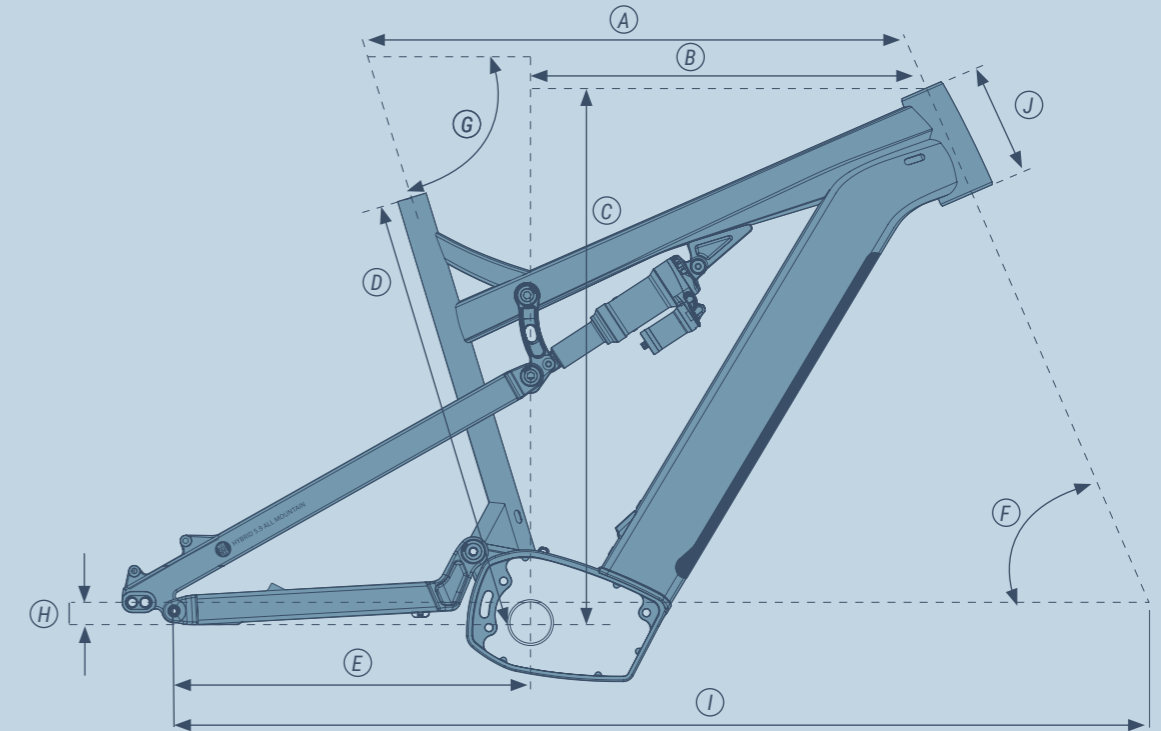

	S		M		L		XL	
	27.5"	29"	27.5"	29"	27.5"	29"	27.5"	29"
A Top tube (horizontal)	578mm	578mm	608mm	608mm	640mm	640mm	670mm	670mm
B Reach	395mm	395mm	425mm	425mm	455mm	455mm	485mm	485mm
C Stack	611mm	611mm	612mm	612mm	621mm	621mm	621mm	621mm
D Seat tube	405mm	405mm	432mm	432mm	478mm	478mm	529mm	529mm
E Chain stay	450mm	465mm	450mm	465mm	450mm	465mm	450mm	465mm
F Steering angle	66°	66°	66°	66°	66°	66°	66°	66°
G Seat angle	72°	72°	72°	72°	72°	72°	72°	72°
H BB drop	7mm	7mm	7mm	7mm	7mm	7mm	7mm	7mm
I Wheelbase	1173mm	1188mm	1203mm	1218mm	1237mm	1252mm	1267mm	1282mm
J Head tube	125mm	125mm	125mm	125mm	135mm	135mm	135mm	135mm

* Prices and equipment subject to change



7.1

NOX HYBRID **ENDURO 7.1** OVER ROUGH AND ROCK.

Do you like extreme, long rides on single trails and over rough terrain? Do you want to have fun riding both uphill and downhill? Are you tired of having to use a shuttle or a lift several times a day to ride your favourite trails? Are the currently available e-bikes not extreme enough for you? Or maybe you're not a fan of the "mounted battery" design?

If your answer to these questions is **YES**, then we have the perfect bike for you: the NOX HYBRID ENDURO 7.1 with 180mm suspension travel represents an optimum symbiosis between muscle power and electric assistance in extreme conditions – for riders who love cycling and unbridled adventures.

DETAILS

- ▶ Wheel sizes 27.5" / 29"
- ▶ Suspension travel 180mm
- ▶ Brose Drive S Alu mid-mounted motor (36V, 250W)
- ▶ BMZ URV8 battery (630Wh)
- ▶ Enduro-specific components
- ▶ Water bottle mounts

SKY

PAPAYA

7.1

ENDURO

PAPAYA



SKY

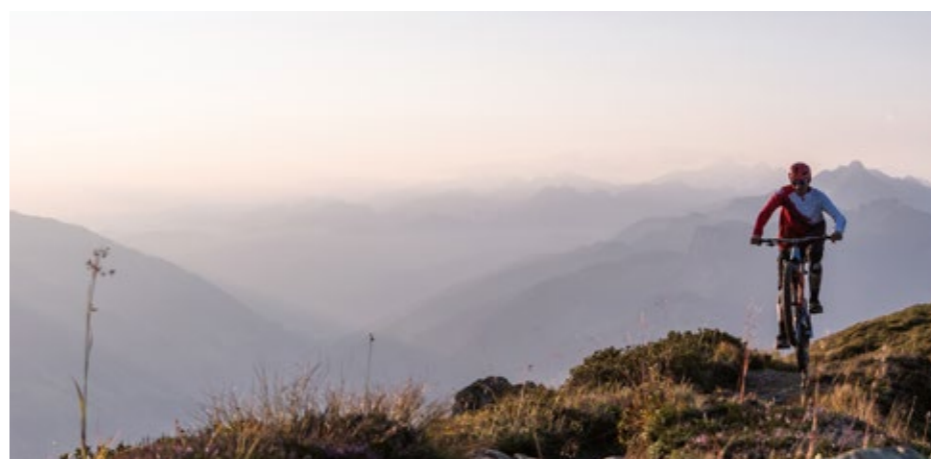

7.1 PRO

DRIVE		EQUIPMENT		€ 6.999,- *	
CRANKSET	SRAM EX1 E-Crank, 165mm, 34T	FRAME	NOX Frame 7.1 Hybrid	SEAT POST	FOX Transfer Factory Post
REAR DERAILLEUR	SRAM X0 Eagle 12fach	FRAME SIZES	S / M / L / XL	SADDLE	PROLOGO Proxim W650
SHIFTER	SRAM X0 Eagle 12fach	FORK	FOX 36 Factory 27.5", 180mm		Microfiber P1 + Grip
CASSETTE	SRAM PG 1230, 11-50T	REAR SHOCK	FOX DHX2	WHEELSET	STAN'S NoTubes Flow 27.5
MOTOR	BROSE Drive-S Unit	STEM	RENTHAL Apex 35	TYRES	CONTINENTAL Der Baron/ TrailKing 27.5x2.4
BATTERY	BMZ Inside UR-V8, 10S5P, 630Wh	HANDLEBAR	RENTHAL Fatbar 35	BRAKES	ProTaction Apex
CHARGER	BMZ Ladegerät 10S, 4.5A WBE (100 -240V)	GRIPS	ERGON GD10 Factory		MAGURA MT7 HC

7.1 EXPERT

DRIVE		EQUIPMENT		€ 5.699,- *	
CRANKSET	SRAM EX1 E-Crank, 165mm, 34T	FRAME	NOX Frame 7.1 Hybrid	SEAT POST	Rock Shox Reverb Stealth, 30.9, 1X
REAR DERAILLEUR	SRAM GX Eagle 12fach	FRAME SIZES	S / M / L / XL	SADDLE	ERGON SM10 E
SHIFTER	SRAM GX Eagle 12fach	FORK	ROCK SHOX Yari Charger RC, 29"/27.5"+, 180mm	WHEELSET	DT SWISS H1700 Spline 27.5
CASSETTE	SRAM PG 1230, 11-50T	REAR SHOCK	ROCK SHOX Super Deluxe RCT Coil	TYRES	CONTINENTAL Der Baron/ TrailKing 27.5x2.4
MOTOR	BROSE Drive-S Unit	STEM	TRUVATIV Descendant 35	BRAKES	ProTaction Apex
BATTERY	BMZ Inside UR-V8, 10S5P, 630Wh	HANDLEBAR	TRUVATIV Descendant 35		MAGURA MT5 HC
CHARGER	BMZ Ladegerät 10S, 4.5A WBE (100 -240V)	GRIPS	ERGON GD10		

7.1 COMP

DRIVE		EQUIPMENT		€ 4.699,- *	
CRANKSET	SRAM EX1 E-Crank, 165mm, 34T	FRAME	NOX Frame 7.1 Hybrid	SEAT POST	NOX Components 30.9mm/400mm
REAR DERAILLEUR	SRAM NX Eagle 12fach	FRAME SIZES	S / M / L / XL	SADDLE	ERGON SM10
SHIFTER	SRAM NX Eagle 12fach	FORK	ROCK SHOX Yari RC 29"/27.5"+, 180mm	WHEELSET	DT SWISS H1900 Spline 27.5
CASSETTE	SRAM PG 1230, 11-50T	REAR SHOCK	Boost, 180mm	TYRES	CONTINENTAL Der Baron/ TrailKing 27.5x2.4
MOTOR	BROSE Drive-S Unit	STEM	NOX COMPONENTS 35	BRAKES	ProTaction Apex
BATTERY	BMZ Inside UR-V8, 10S5P, 630Wh	HANDLEBAR	NOX COMPONENTS 35		MAGURA MT5 HC
CHARGER	BMZ Ladegerät 10S, 4.5A WBE (100 -240V)	GRIPS	ERGON GD10		

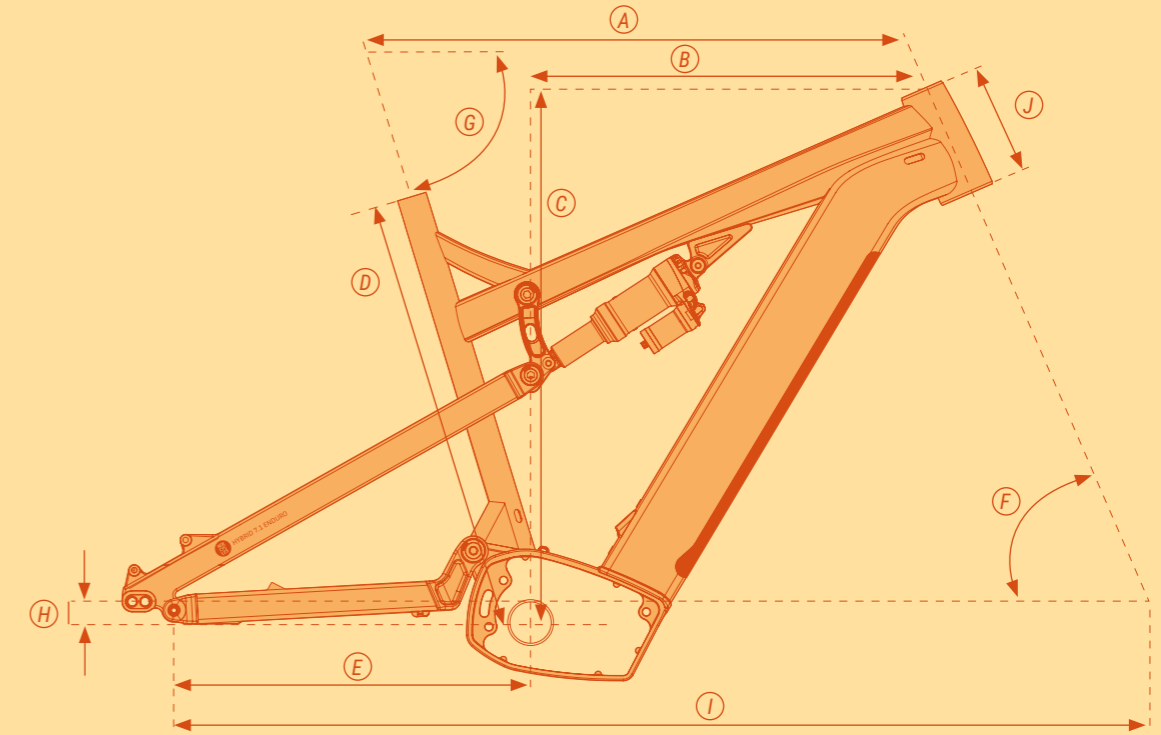

	S		M		L		XL	
	27.5"	29"	27.5"	29"	27.5"	29"	27.5"	29"
A Top tube (horizontal)	580mm	580mm	610mm	610mm	643mm	643mm	673mm	673mm
B Reach	387mm	387mm	417mm	417mm	448mm	448mm	478mm	478mm
C Stack	616mm	616mm	617mm	617mm	627mm	627mm	627mm	627mm
D Seat tube	405mm	405mm	432mm	432mm	478mm	478mm	529mm	529mm
E Chain stay	447mm	462mm	447mm	462mm	447mm	462mm	447mm	462mm
F Steering angle	65°	65°	65°	65°	65°	65°	65°	65°
G Seat angle	72°	72°	72°	72°	72°	72°	72°	72°
H BB drop	12mm	12mm	12mm	12mm	11mm	11mm	11mm	11mm
I Wheelbase	1183mm	1198mm	1213mm	1228mm	1247mm	1263mm	1277mm	1292mm
J Head tube	125mm	125mm	125mm	125mm	135mm	135mm	135mm	135mm

* Prices and equipment subject to change



PERFECT E-BIKE.
PERFECT DAY.

IMPRINT

Nox Cycles Gmbh, Oranienburger Straße 1 - 3
D-10178 Berlin-Mitte
Tel: +49 30 367 53 237
Riders: Nox Employees
Photos: Simon Beizae
Design: Fargo Cir. Studio

Version 2019 - V1.4

A photograph of three mountain bikers on a grassy ridge at sunset. The sun is low on the horizon, creating a warm, golden glow over a range of mountains. The bikers are silhouetted against the bright sky. The foreground is filled with green and yellow wildflowers.

NO
MORE
EXCUSES.

AT **Nox Cycles Austria GmbH**
Rohrerstraße 51
6280 Zell am Ziller
Austria

+43 (0)5282 226 99

DE **Nox Cycles GmbH**
Oranienburger Straße 1 - 3
D-10178 Berlin-Mitte
Germany

+49 (0)30 367 53 237

CH **Nox Cycles Switzerland GmbH**
Grundstrasse 2
6343 Rotkreuz
Switzerland

+41 41 520 05 1 - 0

NOXCYCLES.COM
info@noxcycles.com

